



## FASCIA & BACKBAR

v1

FITTING INSTRUCTIONS

## YOU SHOULD HAVE

### ONE OF THE FOLLOWING BRACKET SETS

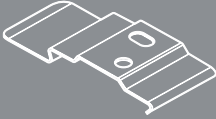
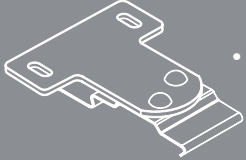
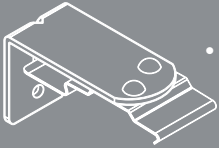
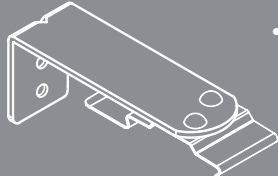
-  • Cassette Top Fix Brackets (standard default bracket)
-  • Cassette Top Fix Extension Brackets
-  • Cassette Face Fix Brackets
-  • Cassette Face Fix Extension Brackets

### SAFETY DEVICES

-  • P Clip
- Tie down safety clip

### COVER CAPS



### TOOLS REQUIRED

- Screwdriver
- Pencil
- Power-Drill
- Tape Measure

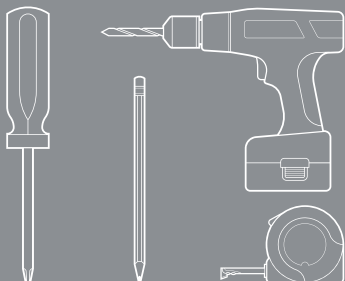

## STEP 1

**THE INSTALLATION OF THIS PRODUCT SHOULD BE CONDUCTED BY SOMEONE COMPETENT IN DIY.**

### OUTSIDE RECESS

If the blind is to be fitted outside the window ensure that measurement C is the same. Follow instructions for FACE FIXING. To calculate C  $(A-B)/2$ .

### INSIDE RECESS

TOP FIX to the lintel. FACE FIX bracket to the window frame.

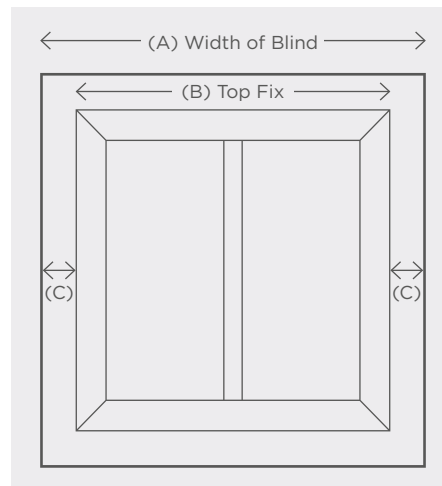

## STEP 2

Carefully unwrap the roller blind and its associated brackets.

The cassette top fix brackets come as standard with all cassette roller blinds unless alternative brackets were selected during time of ordering.

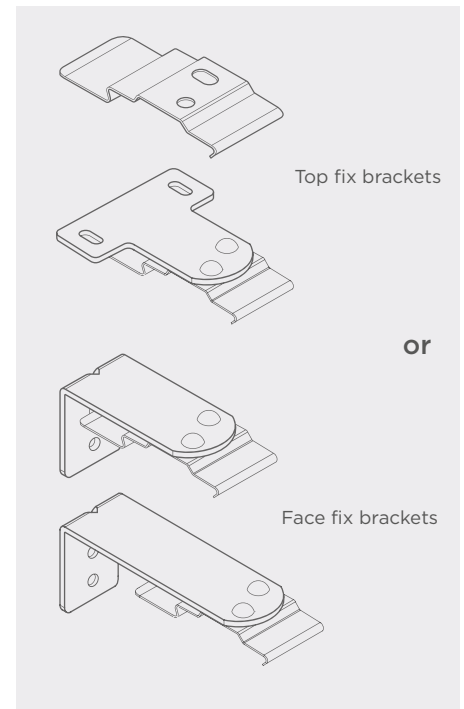

### FITTING THE BRACKETS

For a blind up to 1 metre wide attach two brackets fitted approximately 75mm (3") from each end of the blind (fig. 1). Any intermediate brackets should be spaced evenly between these and as a general rule:

Up to 1m = 2 brackets  
1m to 2m = 3 brackets.  
2m to 3m = 4 brackets.  
Over 3m = 5 brackets.

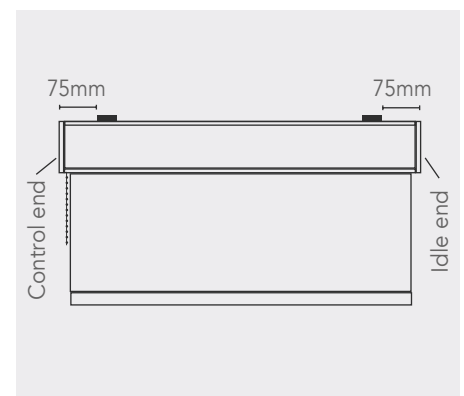

**CHILDREN CAN STRANGLE IF A SAFETY DEVICE IS NOT INSTALLED. ALWAYS USE A SAFETY DEVICE TO KEEP CORDS AND CHAINS OUT OF REACH OF CHILDREN.**

## STEP 2 (CONTINUED)

The bracket release lip on the bracket must face the back of the blind.

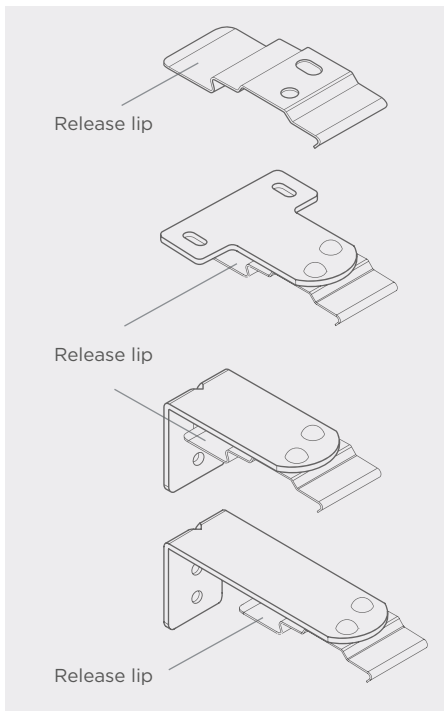

Mark the hole positions before drilling and plugging if necessary. Use two screws in each bracket ensuring that the brackets are level. Remember to allow room for the blind to clear any obstacles when deployed, e.g. door or window handles.

## STEP 3

Place the cassette cover cap onto each side of the headrail.

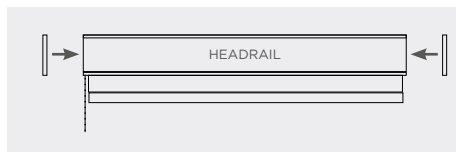

## STEP 4

### FITTING THE CASSETTE

Once all the brackets are in place offer the blind to the brackets. With the cassette tilted away from you locate the front lip into the bracket and push upwards to click the cassette into the back lip of the bracket.

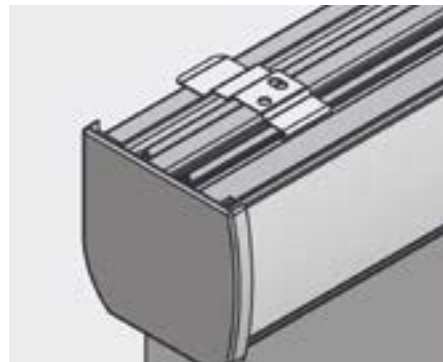
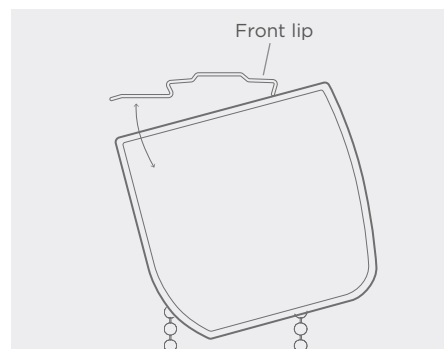

## STEP 5

### SAFETY DEVICE

The safety device must be installed at the maximum distance possible from the control mechanism to prevent looped chain becoming slack.

Place the safety device on the wall and mark the positioning of the 2 screw holes.

Drill holes using a suitable drill bit. Place device into position ensuring the chain is fully taut.

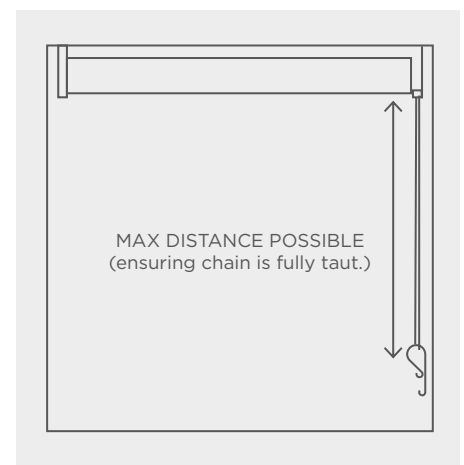

### FITTING THE SAFETY DEVICE

Screw the safety device securely to the wall using suitable fixings.

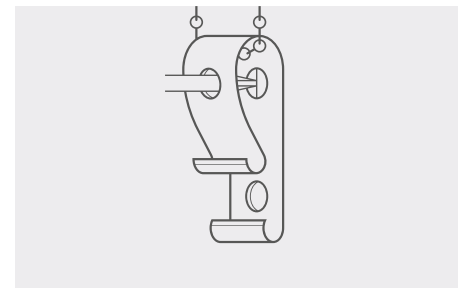

## FABRIC RUN-OFF

Diagram 1 below shows the fabric running off from the right-hand side of the blind. To correct the run-off, unroll the fabric, place a 25mm piece of sticky tape onto the tube (Diagram 2) at the opposite end of the blind to the run-off. Fully wind the blind up. Repeat until the fabric is no longer running-off.

DIAGRAM 1

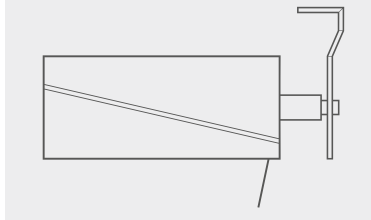
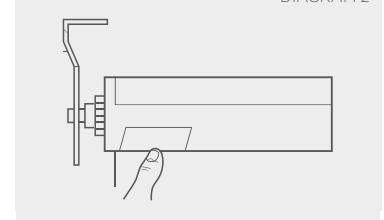

DIAGRAM 2



PLEASE READ THE INSTRUCTIONS BEFORE OPERATING THIS PRODUCT

### STANDARD ROLL

*(Fabric unrolls from behind blind)*

1. To lower the fabric on the roller blind gently pull the operating chain closest to the window.
2. To raise the fabric on the blind gently pull the operating chain furthest from the window.
3. Where possible operating chain should be operated from just above the chain connector as this puts less pressure on this component, reducing the risk of snapping or pulling apart.

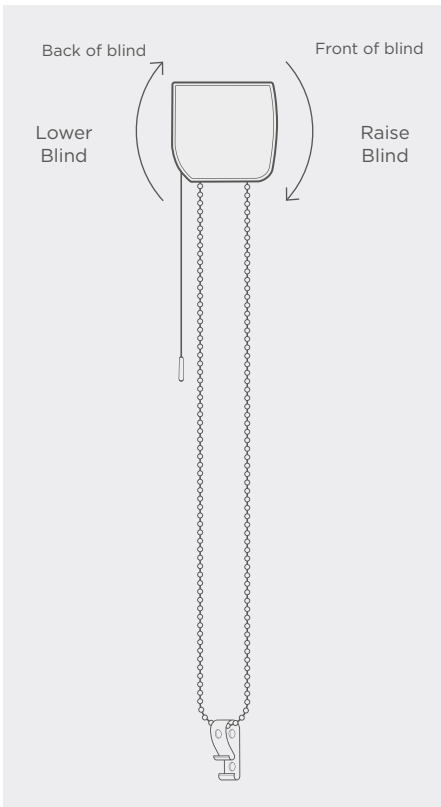

### REVERSE ROLL

*(Fabric unrolls from front of blind)*

1. To lower the fabric on the roller blind gently pull the operating chain furthest from the window.
2. To raise the fabric on the roller blind gently pull the operating chain closest to the window.
3. Where possible operating chain should be operated from just above the chain connector as this puts less pressure on this component, reducing the risk of snapping or pulling apart.

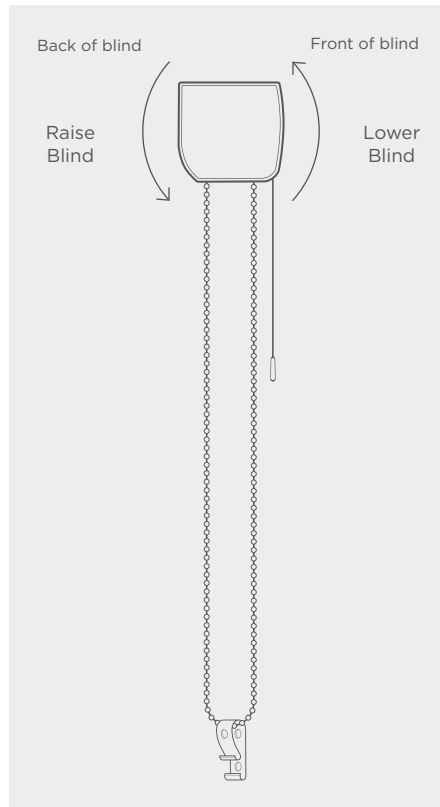

### MAINTENANCE

The product is maintenance free however we recommend that regular visual checks are completed to ensure that no components have been damaged, which could result in operating difficulties and/or cause a safety risk.

If any maintenance is required we recommend that the work is carried out immediately, by a reputable blind company.



**make it  
safe**<sup>TM</sup>

**BBSA**<sup>®</sup>  
BRITISH BLIND & SHUTTER ASSOCIATION

### WARNING

Young children can be strangled by loops in pull cords, chains, tapes and inner cords that operate the product. To avoid strangulation and entanglement, keep cords out of the reach of young children.

Cords may become wrapped around a child's neck.

Move beds, cots and furniture away from window covering cords. Do not tie cords together. Make sure cords do not twist and create a loop.

